

# Nomenclature for Hammer Weight Reference Scales

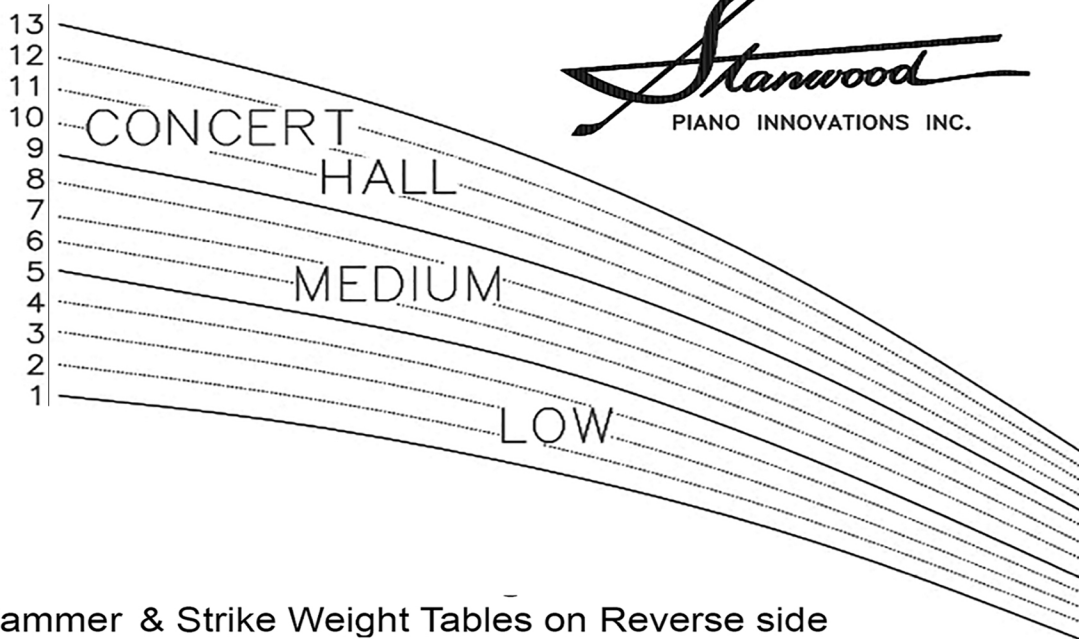

- 13. Top High
- 12. 3/4 High
- 11. 1/2 High
- 10. 1/4 High
- 9. Bottom High
- 8. Top Medium
- 7. 3/4 Medium
- 6. 1/2 Medium
- 5. Bottom Medium
- 4. Top Low
- 3. 3/4 Low
- 2. 1/2 Low
- 1. Bottom Low



Hammer & Strike Weight Tables on Reverse side

## STANDARD PROCEDURES FOR MEASURING HAMMER WEIGHT

### STRIKE WEIGHT (SW)

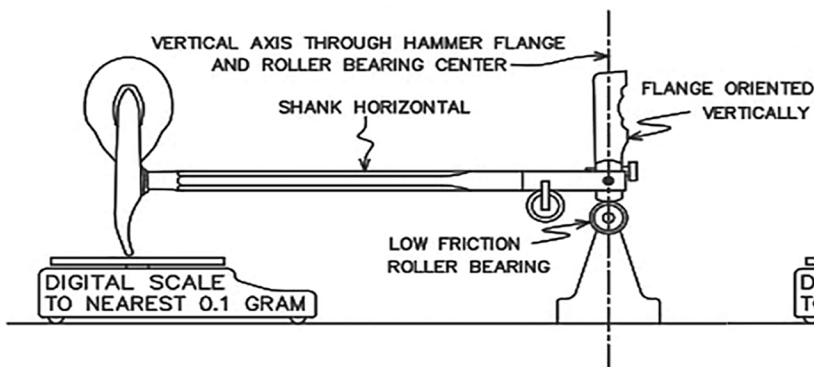

### SHANK STRIKE WEIGHT (SS)

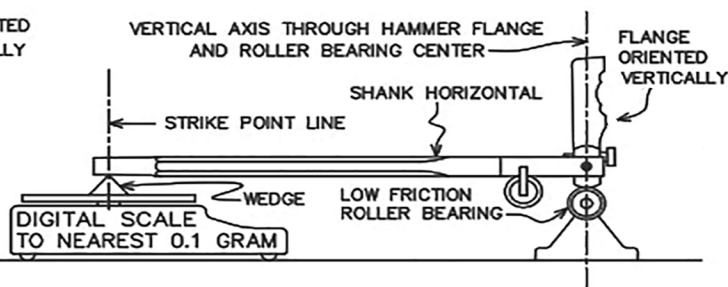

$$SW \approx HW + SS$$

$$HW \approx SW - SS$$

### HAMMER WEIGHT (HW)



### NOTES:

The Hammer Weight reference scales are for rating hammer weight quality and derived from years of empirical data taken from pianos of the late 19th to late 20th century. The scales may be used for hammer weight specifications or custom scales may be created that cross the standard scales as desired.

For best tone, follow these hammer felt quality guidelines: Scale #1 - Lowest density, no crown tension, deepest gradient from soft surface to deep hard, and lowest expected decibel output. Scale #7 - Medium density, medium crown tension, medium gradient from soft surface to deep hard, and medium expected decibel output. Scale #13 - Highest density, highest crown tension, shallowest gradient from soft surface to deep hard, and highest expected decibel output. - David Stanwood



Strike Weight reference scales in grams

Hammer Weight reference scales (SW-1.8g)

Table with 26 columns (Note 1-13) and 26 rows (1-26). Each cell contains a numerical value representing a weight reference scale. The table is organized into two main sections: Strike Weight reference scales in grams (left) and Hammer Weight reference scales (SW-1.8g) (right).